

## FILTRO + DEPURATORE FILTER + DEPURATOR • FILTRE + ÉPURATEUR

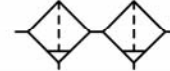

SIMBOLO PNEUMATICO  
PNEUMATIC SYMBOL  
SYMBÔLE PNEUMATIQUE



CODICE ORDINE  
ORDER CODE  
CODE COMMANDE

Mod.	Filetto Thread • Filetage
FDM	1/8
FDM	1/4
FDM	3/8
FDM	1/2

### DIMENSIONI • SIZE • DIMENSION

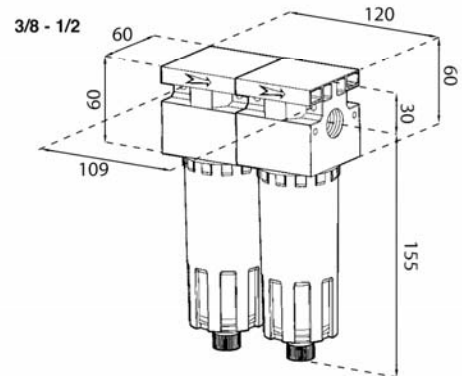
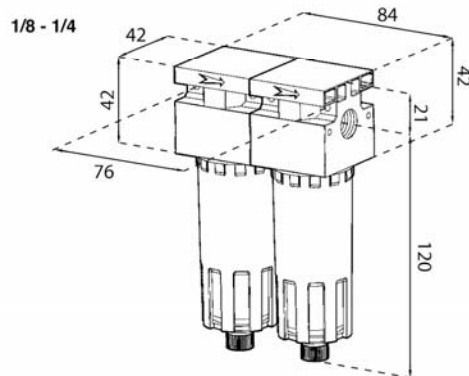

F-R-L UNITS

### DATI TECNICI • TECHNICAL DATA • CARACTÉRISTIQUES TECHNIQUES

	1/8 - 1/4	3/8 - 1/2
Peso • Weight • Poids	0,8 Kg	1,8 Kg
Viti di fissaggio a parete • Wall fixing screws • Vis de fixation au mur	M4x40	M4x50
Scarico condensa Condensate drain Purge des condensats	manuale/semiautomatico • manual/semiautomatic • manuelle/semiautomatique A richiesta scarico condensa automatico (accessori mod. SA) By request automatic drain system (accessories mod. SA) Sur demande purge des condensats automatique (accessoire mod.SA)	
Pressione max di ingresso • Maximum inlet pressure • Pression maximale d'entrée	bar 18 - psi 261 - kPa 1800 - MPa 1,8	
Pressione max con scarico di condensa automatico Maximum inlet pressure with automatic drain Pression maximale d'entrée avec purge des condensats automatique	10 bar	
Temperatura max a 10 bar • Maximum temperature at 10 bar Température maximale à 10 bars (145 psi - 1000 kPa - 1 MPa)	+50° -25° C	
Grado di filtrazione • Degree of filtration • Degré de filtration	4 µm	
Grado di depurazione • Degree of depuration • Degré d'épuration	99,97% a 0,01 µm • 99,97% at 0,01 µm • 99,97% à 0,01 µm	
Fluido • Fluid • Fluide	aria compressa • compressed air • air comprimé	