



I cilindri serie CZ di Airwork sono realizzati rispettando la normativa ISO 15552 ed hanno alesaggi compresi fra 32 e 125 mm. Doppio effetto, ammortizzati e magnetici sono indicati dove è richiesta precisione ed affidabilità. Il nuovo profilo della camicia rende il prodotto interessante anche dal punto di vista estetico. Possibili realizzazioni speciali a disegno e guarnizioni in Viton per alte temperature.

The cylinders of the CZ series are produced complying with the ISO 15552 norm; they have bores comprised between 32 and 125 mm. Particularly indicated where precision is important, they are available in different versions: double effect, cushioned and magnetic. The production of special cylinders on customer's drawing is possible, as well as the realization of versions with VISON seals.

CHIAVE DI CODIFICA / KEY TO TYPE NUMBER

CZ_00_1_000_0000

- CORSA / STROKE
- Ø CILINDRO / Ø CYLINDER
- GUARNIZIONI / SEALS
 - 1 = POLIURETANO / POLYURETHANE
 - 4 = GUARNIZIONE STELO PER USO PESANTE / SEAL ROD FOR HARD USE
 - 3 = VITON / VITON
 - 6 = VITON SOLO STELO / VITON ONLY ROD
- VERSIONE - VERSION
 - 01 = DOPPIO EFFETTO / DOUBLE ACTING
 - 03 = STELO PASSANTE / THROUGH ROD
 - 05 = CON EXTRASTELO PER BS / FOR ROD LOCK BS SERIES
 - 29 = CON EXTRASTELO PER BA / FOR ROD LOCK BA SERIES
 - 07 = CON STELO INOX / WITH INOX ROD
 - 21 = TANDEM DOPPIA SPINTA / TANDEM DOUBLE PUSH
 - 23 = TANDEM DOPPIA CORSA / TANDEM DOUBLE STROKE
 - 25 = TANDEM CONTRAPPOSTI / TANDEM CONTRASTED
 - 31 = CON SOFFIETTO / WITH RUBBER BELLOW
 - 33 = CON BLOCCASTELO SERIE BS MONTATO / WITH ROD LOCK BS SERIES ASSEMBLED
 - 35 = CON BLOCCASTELO SERIE BA MONTATO / WITH ROD LOCK BA SERIES ASSEMBLED

VERSIONE - VERSION

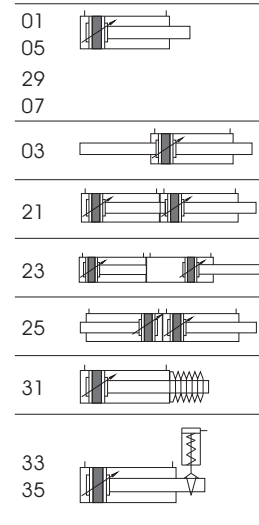

DATI TECNICI / TECHNICAL DATA

Alesaggi - Sizes	Ø32-40-50-63-80-100-125
Corse standard - Standard strokes	mm 25-50-80-100-125-160-200-250-320-350-400-500-600-700-800-900-1000
Fluido - Fluid	Aria con o senza lubrificazione - Lubricated or non lubricated air
Temperatura di esercizio - Operating temperature range	Poliuretano : -20C°+80C° / Viton: -10C°+150C°
Pressione massima di esercizio - Max operating pressure	10 bar
Forze sviluppate - Force	pag.datì tecnici / technical informations page
Consumo aria - Air consumption	pag.datì tecnici / technical informations page

PROFILO TUBO / TUBE PROFILE

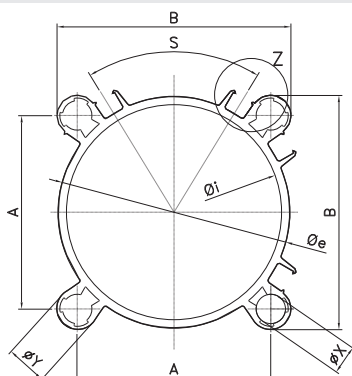

Øi	Øe	QUOTE				
		A	B	ØX	ØY	S
32 ^{H11}	36	32.5	42.5	5.4	10	46°
40 ^{H11}	44.2	38	48	5.4	10	51°
50 ^{H11}	54.4	46.5	59.5	7.4	13	54°
63 ^{H11}	67.7	56.5	69.5	7.4	13	61°
80 ^{H11}	85.5	72	86	9.1	14	65°
100 ^{H12}	105.5	89	105.5	9.1	16.5	68°
125 ^{H12}	131	110	131	10.6	17	70°

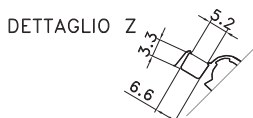

COMPONENTI / COMPONENTS

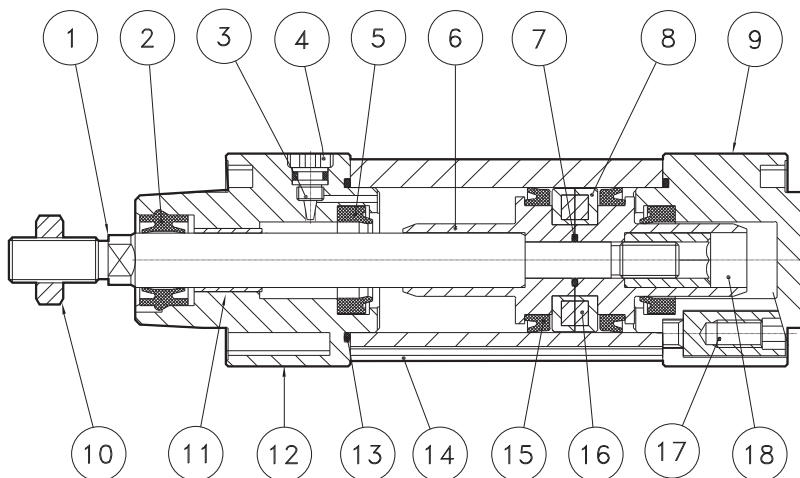

pos.	descrizione / description	materiale / material
1	stelo / rod	acciaio C40 cromato / steel C40 chromed
2	guarnizione stelo / rod seal	poliuretano / polyurethane
3	vite reg. ammortizzo / regulator cushion screw	ottone nichelato / nickel brass
4	grano ferma vite / stop cushion srew	ottone nichelato / nickel brass
5	guarnizione ammortizzo / cushion seal	poliuretano / polyurethane
6	semipistone / half piston	POM
7	o-ring	NBR
8	guida pistone / guide piston	POM
9	testata posteriore / rear cap	alluminio / aluminium
10	dado / nut	acciaio zincato / steel zinc plate
11	bussola guida / guide bush	PTFE 32-63 bronze 80-125
12	testata anteriore / front cap	alluminio / aluminium
13	o-ring	NBR
14	tubo / tube	alluminio / aluminium
15	guarnizione pistone / piston seal	poliuretano / polyurethane
16	magnete / magnet	plastoferrite
17	vite serraggio testata / fixing cap screw	acciaio zincato / steel zinc plate
18	dado fissaggio pistone / fixing piston nut	acciaio zincato / steel zinc plate

SEZIONE / SECTION

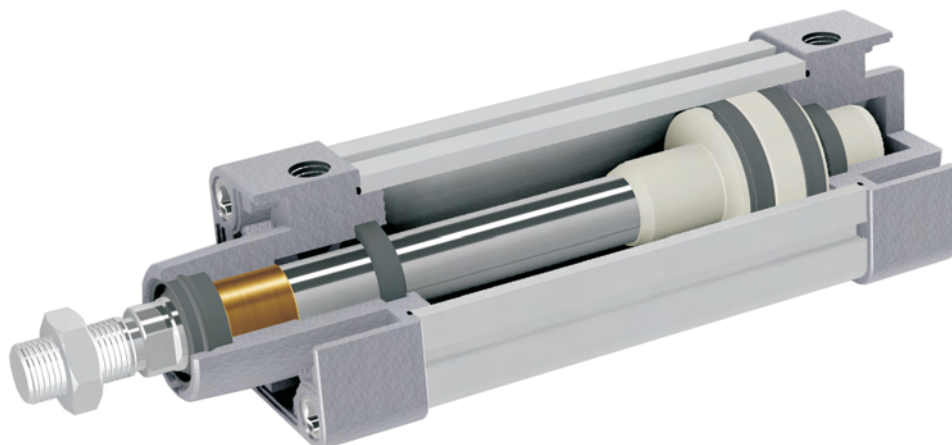

DOPPIO EFFETTO
DOUBLE ACTING

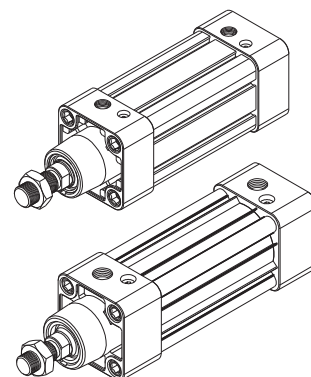
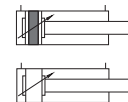
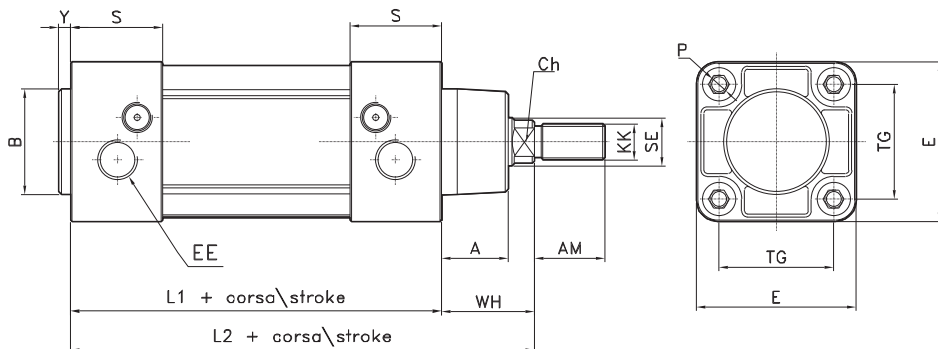

∅	A	AM (-2)	B ø11	E	EE	Y (-1)	KK	L1	L2	P	S	SE ∅	TG	WH	Ch
32	20	22	30	47	G1/8"	4	M10x1.25	94 ± 0.4	120	M6	28	12	32.5	26	10
40	22	24	35	53	G1/4"	4	M12x1.25	105 ± 0.7	135	M6	30.5	16	38	30	13
50	28	32	40	65	G1/4"	4	M16x1.5	106 ± 0.7	143	M8	31	20	46.5	37	16
63	28	32	45	75	G3/8"	4	M16x1.5	121 ± 0.8	158	M8	35	20	56.5	37	16
80	34	40	45	95	G3/8"	4	M20x1.5	128 ± 0.8	174	M10	36	25	72	46	21
100	38	40	55	115	G1/2"	4	M20x1.5	138 ± 1	189	M10	41	25	89	51	21
125	50	54	60	140	G1/2"	5	M27x2	160 ± 1	225	M12	45	32	110	65	27

STELO PASSANTE
THROUGH ROD

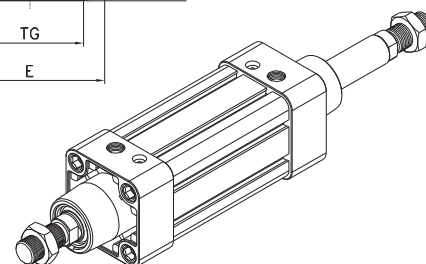
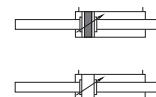
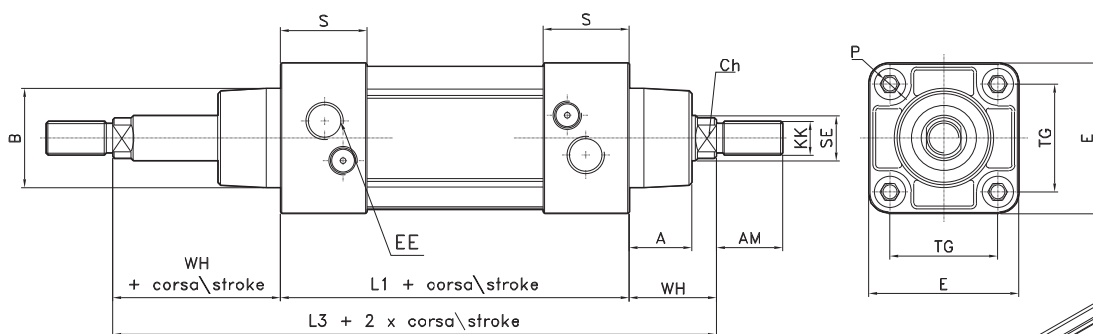

∅	A	AM (-2)	B ø11	E	EE	KK	L1	L2	L3	P	S	SE ∅	TG	WH	Ch
32	20	22	30	47	G1/8"	M10x1.25	94 ± 0.4	120	146 ± 0.4	M6	28	12	32.5	26	10
40	22	24	35	53	G1/4"	M12x1.25	105 ± 0.7	136	165 ± 0.7	M6	30.5	16	38	30	13
50	28	32	40	65	G1/4"	M16x1.5	106 ± 0.7	143	180 ± 0.7	M8	31	20	46.5	37	16
63	28	32	45	75	G3/8"	M16x1.5	121 ± 0.8	158	195 ± 0.8	M8	35	20	56.5	37	16
80	34	40	45	95	G3/8"	M20x1.5	128 ± 0.8	174	220 ± 0.8	M10	36	25	72	46	21
100	38	40	55	115	G1/2"	M20x1.5	138 ± 1	189	240 ± 1	M10	41	25	89	51	21
125	50	54	60	140	G1/2"	M27x2	160 ± 1	225	290 ± 1	M12	45	32	110	65	27

TANDEM DOPPIA SPINTA
TANDEM DOUBLE PUSH



TANDEM DOPPIA CORSA
TANDEM DOUBLE STROKE

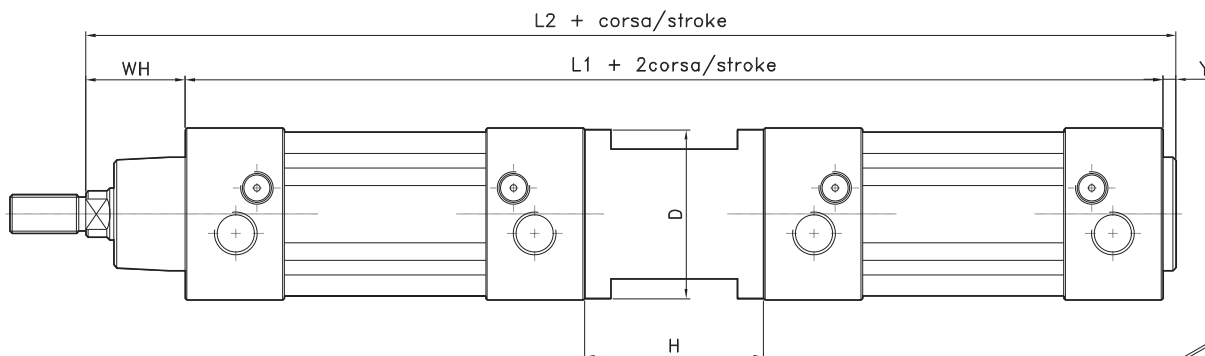

Ø	H	D	WH	L1	L2	Y
32	55	45	26	243 ± 0.4	273	4
40	55	52	30	265 ± 0.7	299	4
50	68	65	37	280 ± 0.7	321	4
63	68	75	37	314 ± 0.8	351	4
80	92	95	46	348 ± 0.8	398	4
100	92	115	51	368 ± 1	423	4
125	120	140	65	440 ± 1	510	5

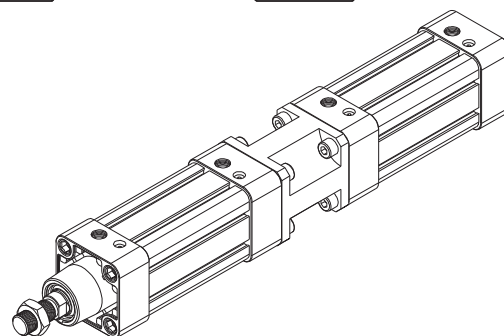

TANDEM CONTRAPPOSTI
TANDEM CONTRASTED

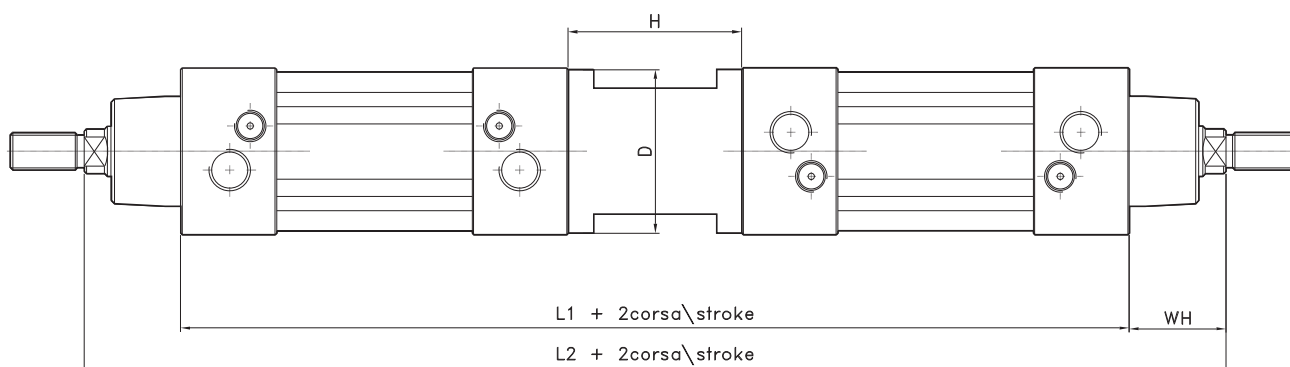

Ø	H	D	WH	L1	L2
32	55	45	26	243 ± 0.4	295
40	55	52	30	265 ± 0.7	325
50	68	65	37	280 ± 0.7	354
63	68	75	37	310 ± 0.8	384
80	92	95	46	348 ± 0.8	440
100	92	115	51	368 ± 1	470
125	120	140	65	440 ± 1	570

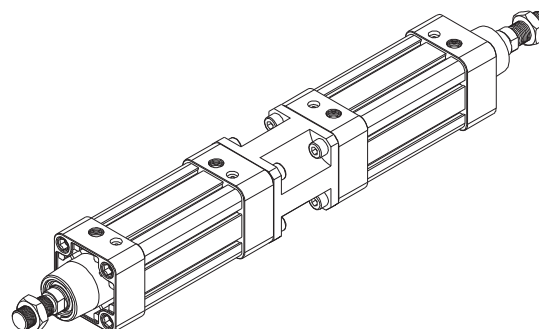

CON SOFFIETTO
WITH RUBBER BELLOW

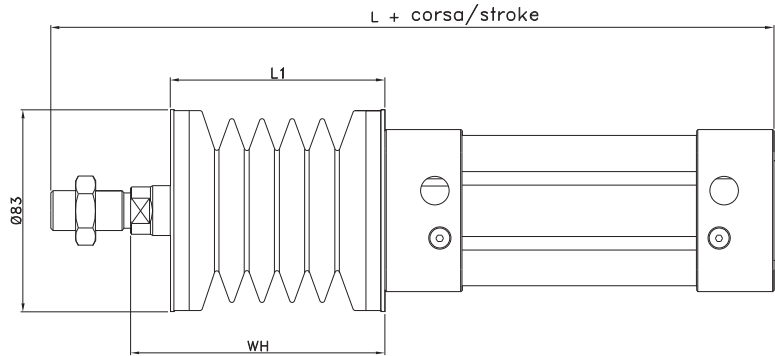
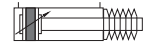

Ø	STROKE <400 mm			STROKE <800 mm			STROKE <1200 mm		
	L	L1	WH	L	L1	WH	L	L1	WH
32	222	90	106	274	142	158	332	200	216
40	235	90	106	287	142	158	345	200	216
50	244	90	106	296	142	158	354	200	216
63	259	90	106	311	142	158	369	200	216
80	274	90	106	326	142	158	384	200	216
100	284	90	106	336	142	158	394	200	216

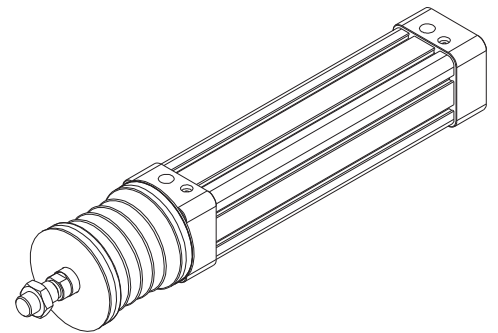

CON BLOCCASTELO SERIE BS MONTATO
WITH ROD LOCK BS SERIES ASSEMBLED

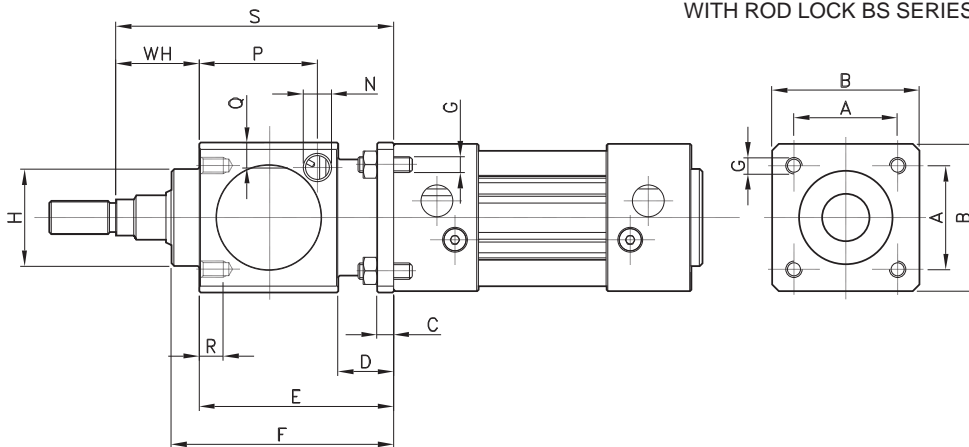
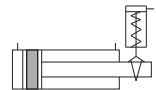

Ø	A	B	C	D	E	F	G	H	N	P	Q	R	S	T
32	32.5	47	6	20	60	67.5	M6	30	1/8"G	33.25	9	8	86	60
40	38	54	6	20	70	80	M6	34.9	1/8"G	42.5	9	8	100	70
50	46.5	65	8	24	90	100	M8	40	1/8"G	58	12.5	12	127	90
63	56.5	75	8	24	90	100	M8	45	1/8"G	59	17.5	12	127	90
80	72	95	12	32	110	120	M10	45	1/4"G	69	17.5	16	156	110
100	89	114	12	32	110	120	M10	55	1/4"G	69	20	16	161	110
125	110	138	20	45	140	156	M12	60	1/4"G	84.5	19	20	205	140

